



# Perimeter protection systems

**NEW: Hörmann OktaBlock mobile vehicle blocker**

Certified according to BSI PAS68:2013 and IWA-14-1:2013  
or the technical guidelines of the German police for mobile vehicle blockers

**HÖRMANN**

# Hörmann OktaBlock mobile vehicle blocker

Certified according to BSI PAS68:2013 and IWA-14-1:2013 or the technical guidelines of the German police for mobile vehicle blockers



## Certified personal protection

The Hörmann OktaBlock mobile vehicle blocker secures driveways and access to open-air events and effectively prevents vehicles from smashing through.

The vehicle blocker is certified as a **single module** according to the following crash test standards:

### International standards BSI PAS68:2013 and IWA-14-1:2013 standardised crash test "N2/N2A"

In this standardised crash test, an unmanned N2 / N2A category truck with a **test weight of 7.5 tonnes and a speed of 50 km/h** drives against a barrier. The resulting impact energy is 750000 joules.

or

### Technical guidelines of the German police for mobile vehicle blockers

In this even more stringent test, an impact below 90° as well as below 45° is carried out. In addition, the test takes place on wet roads and the vehicle may no longer be roadworthy after the impact. The maximum impact energy in this test is up to 986000 joules.

By certifying a **single** module, it is not necessary to connect multiple modules, contrary to many competitive products. This guarantees maximum flexibility and ensures escape routes.

## Maximum flexibility

Whether its a city festival in springtime, a summer festival or a Christmas market in winter, mobile vehicle blockers **allow the different events to be secured in a location-independent and cost-efficient way at flexible times.** In addition, you save costs in structural measures at each venue, which are required for fixed security bollards or blockers. Ground anchoring or installing supply lines is not necessary for assembly and operation.

Due to its axisymmetric geometry, the Hörmann OktaBlock **has no predefined impact side and can thus prevent a vehicle collision from any direction.** Assembly of the blockers is therefore very simple and highly flexible. The systems ideally complement permanently installed perimeter protection systems in areas where fastenings in the subsurface are not possible for structural reasons.

Protection against vehicle impacts from any direction due to the axisymmetric design

## Individual security concepts

The OktaBlock blockers can be **arranged individually, in rows or offset**. As a result, **individual protection concepts can be implemented that are tailored to your specific requirements**. In addition, the blockers provide unobstructed escape routes all the time without impairing visibility.

The Hörmann OktaBlock is equally suitable for narrow streets and pavements or bike paths, which can often be effectively secured with just one module according to standards. **Blockers with unlimited width** are possible, as well as a sluice arrangement or defined passage points for emergency and rescue vehicles.

The design of the Hörmann OktaBlock is inconspicuous, and is therefore not perceived to be threatening.



The figure shows the OktaBlock TR

## Simple logistics

The **fully assembled individual blockers** can be positioned with a standard crane truck or forklift truck and can be quickly and easily put up and taken down on-site without special technical knowledge.

The blocker can be easily moved with a crane or forklift using an **M20 eyelet in the bollard top**.

In addition, the innovative vehicle blocker is **tamper-proof and does not need to be guarded** before and during the event. The individual elements can be stored outdoors and transported on standard lorries in a space-saving manner.



Perimeter Protection Systems  
Hörmann

The full product range for perimeter protection can be found in the Perimeter protection systems brochure.

# Hörmann OktaBlock mobile vehicle blocker

Certified according to BSI PAS68:2013 and IWA-14-1:2013 or the technical guidelines of the German police for mobile vehicle blockers

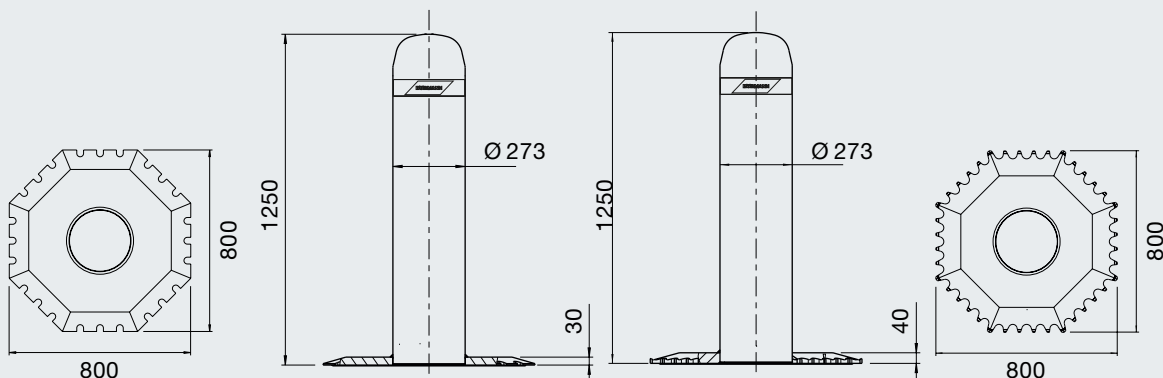

	OktaBlock	OktaBlock TR
Base plate dimensions	800 × 800 mm	800 × 800 mm
Bollard height	1250 mm	1250 mm
Bollard diameter	273 mm	273 mm
Colour	Anthracite grey RAL 7016*	Anthracite grey RAL 7016*
Weight	Approx. 350 kg	Approx. 450 kg
Impact energy	750000 J	986000 J
Certified acc. to	M30, K4, PAS68, IWA14-1	SK1B, TR Pol**

\* Optionally in RAL to choose at a surcharge

\*\*According to the technical guidelines of the German police for mobile vehicle blockers, version 0.8

## Arrangement variants

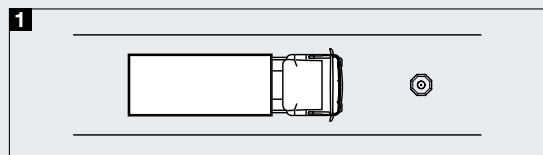

1 Blocker for narrow streets and inner cities

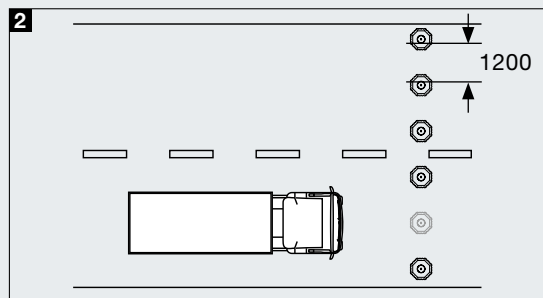

2 Blocker with unlimited width enabling the quick and easy set-up of passage points for authorised vehicles

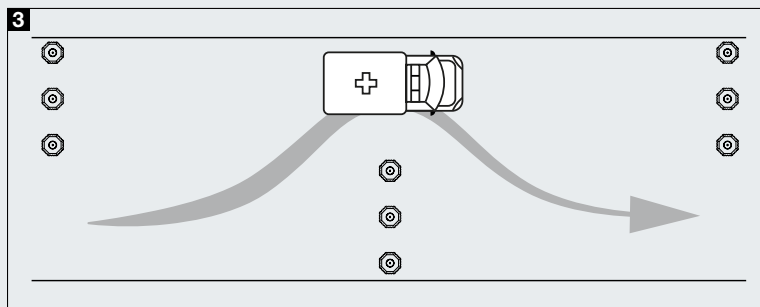

3 Deflector sluce passable by authorised vehicles

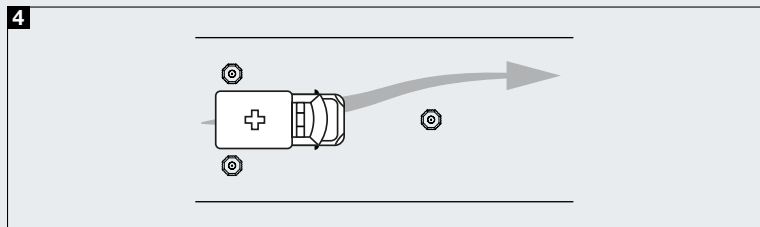

4 V-slucce passable by authorised vehicles

All details in mm